

BG-100 Wire Clamp

Fitting Instructions

EN

Use

IronGrip's BG-100 wire clamp can be used for all types of lifting device and suspended load. It is intended for use with steel wire ropes with a steel or fibre core for general applications up to and including strength class 1,960 N/mm². Plastic-coated wires are not suitable for lifting applications using IronGrip wire clamps.

Restrictions and requirements

In use for lifting applications, **two** wire clamps per attachment must be used in accordance with these instructions. This applies to all dimensions with BG-600, BG-800, BG-1000, BG-1200, BG-1600, BG-2000, BG-2500 and BG-3400.

The BG-100 can be used with steel wire ropes for general lifting purposes including lifts etc. up to and including strength class 1,960 N/mm². Note that lifting application refers to both static lifting (suspended loads) and dynamic lifting.

Standards

For approval of IronGrip's BG-100 wire clamp for lifting applications the standard SS-EN 13411-3 regarding ferrules has been used. The IronGrip BG-100 wire clamp has been tested in accordance with the same standards, and easily meets the requirements for ferrules, provided the right number of wire clamps per attachment are fitted in accordance with these instructions.

Wire clamp	Wire (mm)	Torque (Nm)	Bending length (mm)	Weight (kg)	Key width (mm)
BG-600	5–6	9,5	180	0,09	10
BG-800	7–8	9,5	220	0,12	10
BG-1000	9–10	22	270	0,20	13
BG-1200	11–12,5	44	330	0,39	16
BG-1600	13–16	75	430	0,72	18
BG-2000	17–20	120	530	1,18	21
BG-2500	21–25	260	700	2,80	27
BG-3400	26–34	350	1100	7,70	30

WARNING

- Failure to follow these fitting instructions may have serious consequences and may cause injury/damage.
- Read the instructions carefully before you start the fitting.
- Tighten using a torque wrench so as to achieve the correct tension in the wire clamps.
- Always oil the bolt threads before tightening. If you do not do this the stipulated torque will not create the right tension.
- Test-load the application with the maximum permissible force, then check the torque again.
- Inspect the attachment regularly.
- Note that the wire clamp's teeth can absorb minor displacement forces. If a tooth breaks off, this is an important sign that undesirable sliding has occurred. Reduce the load immediately, check the attachment and replace the wire clamp.

1. Check that the cable and the wire clamps are undamaged and that the threads are clean and lubricated. Thread lubrication is particularly important in lifting applications, so as to achieve the right traction in the screws.

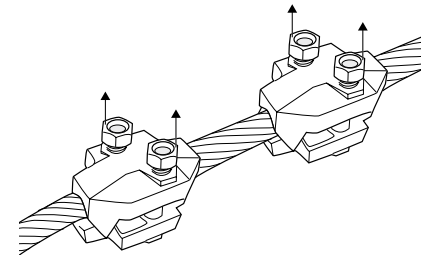
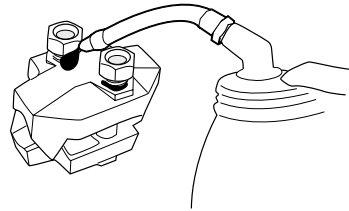

2. Screw the nuts as far back on the bolts as possible. Thread the wire through both wire clamps.

3. Measure out the requisite bending length in accordance with the table. Bend the wire and feed the end back through the wire clamps.

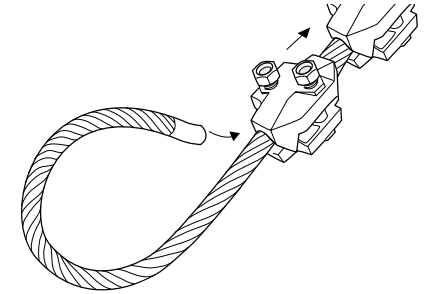

4. Tighten the nuts a little on the wire clamp nearest the end.

5. Insert the thimble, squeeze together the cable and push the wire clamp as close to the thimble as possible. Press against the first fixed clamp.

The distance from the thimble must be about one wire diameter. The wire clamp nearest the thimble must be so close that there is no risk of the thimble loosening when the wire clamp is tightened.

6. Make sure the wire clamp is as straight and symmetrical on the wire as possible.

7. Tighten the nuts alternately so that the teeth fit into the recesses on each side. **NB: Use a torque wrench!** Tighten until the right torque has been achieved.

When tightening the BG-3400, the middle nuts must first be tightened alternately until the right torque has been achieved. The two outer nuts must then be tightened. Finally ensure that all nuts are tightened to the right torque.

8. When the wire clamp closest to the thimble is well tightened, the wire clamp closest to the end can be loosened and if necessary adjusted so that it is at a suitable distance from the other clamp. Tighten the nuts on this lock in accordance with 7) above.

9. The distances between wire clamp, thimble and free end must be as follows:

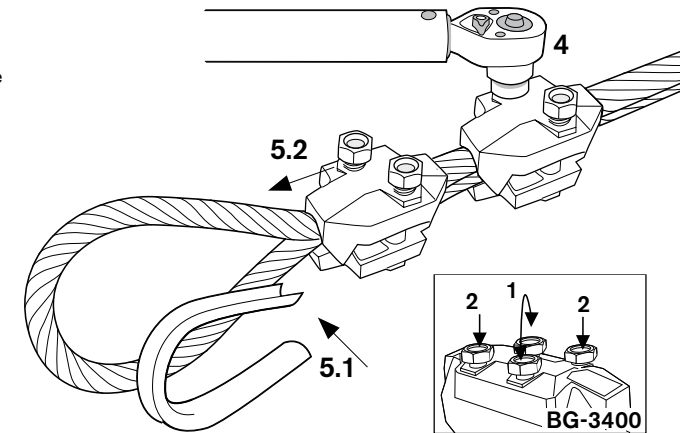
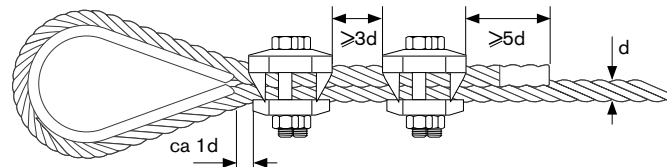

IronGrip BG-100 Wire Clamps

Technical Specifications

Name	Wire Diameter (mm)	Length (mm)	Width (mm)	Weight (kg)	No. of Bolts	Bolt Dimension	Rec. Torque (Nm)
BG-600	5-6	32	26	0.09	2	M6*35	9.5
BG-800	7-8	36	28	0.12	2	M6*40	9.5
BG-1000	9-10	44	34	0.20	2	M8*50	22.5
BG-1200	11-12,5	54	42	0.39	2	M10*60	44
BG-1600	13-16	68	52	0.72	2	M12*75	75
BG-2000	17-20	82	60	1.18	2	M14*90	120
BG-2500	21-25	122	80	2.80	2	M18*110 f.t.	260
BG-3400	26-34	214	94	7.70	4	M20*150 f.t.	360

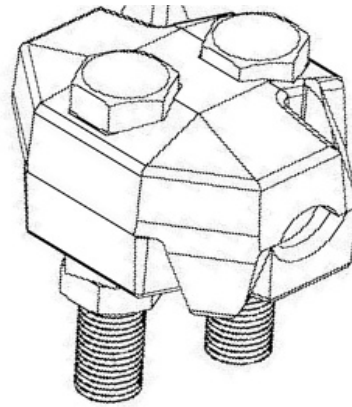
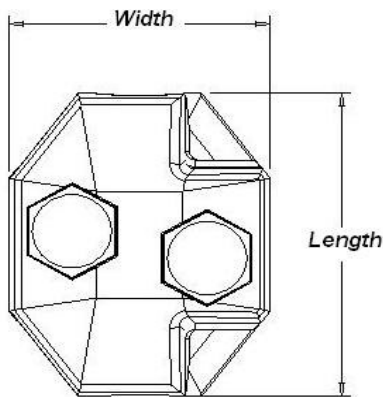

Material Specification:

Castings in ductile cast iron

Strength class for bolts: 8.8 in accordance with ISO 3506

Rustproofing of castings: Hot dip galvanisation in accordance with ISO 1461

Rustproofing of bolts: Electrically galvanised in accordance with ISO 2081

Recommended for all kinds of lifting applications with two wire clamps per fixation for wire ropes of tenacity class including 1960 N/mm²

Tested and approved according to EN 13411-3:2004